

## TECHNICAL SPECIFICATIONS

### GCS-P3015 S

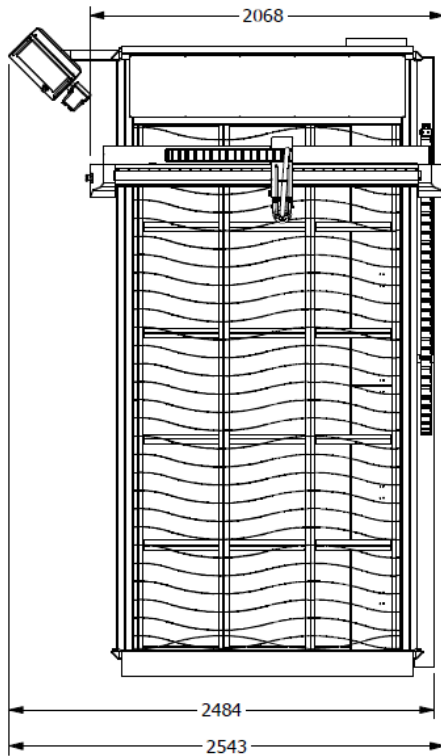

#### DETALLE CABEZAL

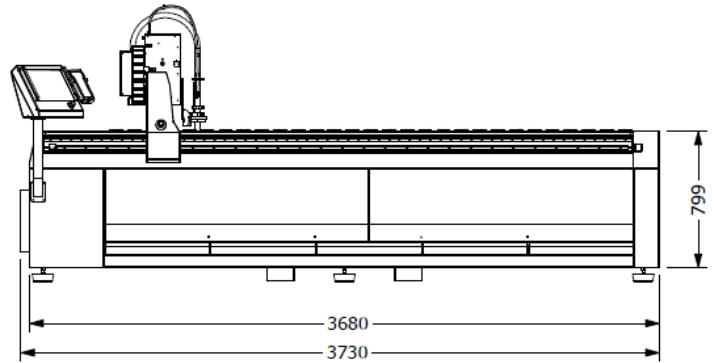
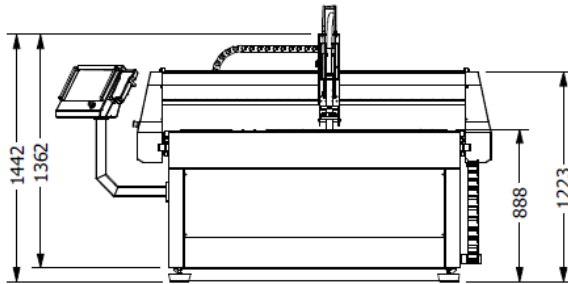
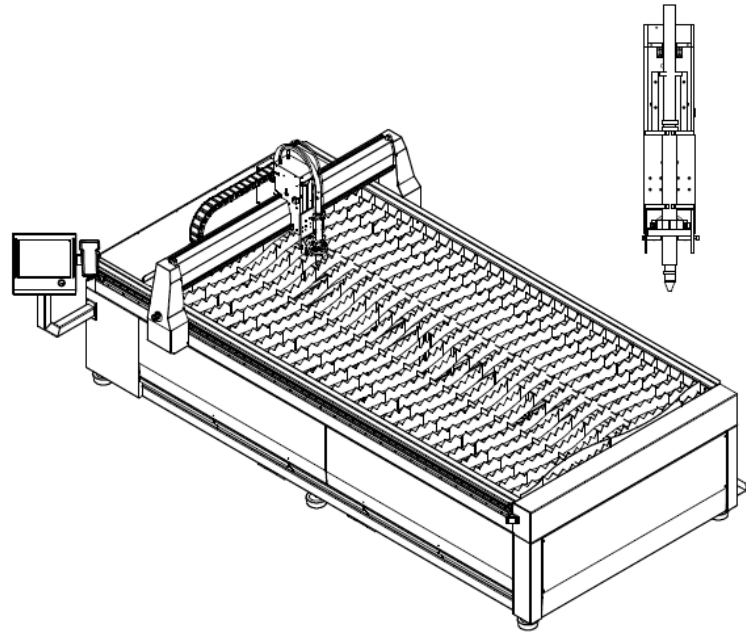

<b>NUMERICAL CONTROL:</b>	Tex Computer Power J + SVGA 10"	<b>MOTORS:</b>	Motor PaP SANYO DENKI 4A Nema 24 30Ncm. Gear 1:3
<b>SPEED:</b>	350mm/s	<b>INSTALLATION REQUIREMENTS:</b>	Pneumatic installation: 6-7 Bar. 50l/m Electric installation: 3P+N+PE 400v 20A sectorized fumes extraction
<b>RESOLUTION:</b>	0,01 mm	<b>HEAD:</b>	THC Automatic height control system
<b>WORKING DIMENSIONS:</b>	3000 x 1500 x 140 mm	<b>CONSUMPTION:</b>	4570 W (With extraction system) 1570 W (Without extraction system)
<b>MOVEMENT SYSTEM:</b>	Linear ball guides	<b>MACHINE DIMENSIONS:</b>	3730 x 2543 x 1442 mm
<b>TRANSMISSION:</b>	Ball screw (Z axis) Helical rack (X & Y axis)	<b>WEIGHT:</b>	950 Kg