



# MU IV

TIG - With or without filler wire, AVC, OSC

## Open welding head

for welding of tube to tube joints,  
tube to elbow joints...



**POLYSOUDE**  
THE ART OF WELDING

# MU IV Open welding head

for welding of tube to tube joints, tube to elbow joints...

A range of modular standard welding heads, perfectly adapted to your needs

## Advantages

- ▶ Productivity increase of more than one third
- ▶ Easy to use
- ▶ Challenging applications, even with delicate materials, can be welded
- ▶ Quick to set-up according to the workload making variations in production capacity trouble free
- ▶ Precision engineered assemblies for a lifetime of trouble-free service

Resulting from 50 years' experience in mastering welding technologies



MU IV for use with external wire feeder

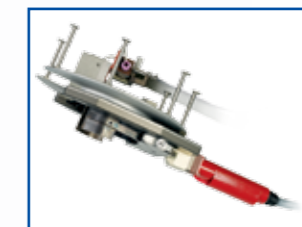

Drive motor with angle gearbox for reduced axial clearance



MU IV with integrated wire feeder



MU IV with AVC/OSC

## Associated Power Sources



### ▶ PS 164-2

160 A, "all inclusive", portable, single-phase power supply



### ▶ P4

170 A, "modular", portable, programming by PC or touch screen, single-phase power supply



### ▶ P6

300 A, "all applications", programming by PC or touch screen, with Arc Voltage Control (AVC) and Torch Oscillation Control (OSC), three-phase power supply

## Wire feeders



### ▶ Polyfil series

External portable wire feeders with spool protection



 Adapted for all your applications!



*"As working conditions are better than in manual welding, a welding operator accomplishes on average 30% more welds per day."*

# Technical specifications

Cable length: 9m

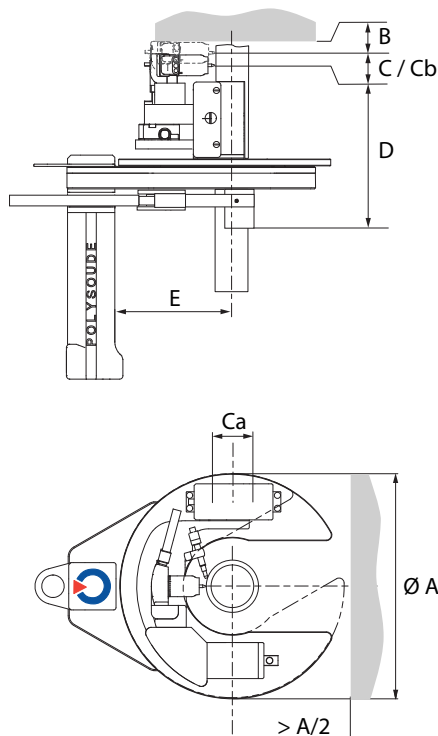

P – Chuck clamping system  
 C – Shell clamping system  
 NA = Non Applicable  
 ◆ = reduced

	Type	Dimensions in mm					
		Double clamping system recommended Min. O.D. / Max. O.D.	Ø A (mm)	B (mm)	C (mm)	D (mm)	E (mm)
P-clamping – adjustable for the entire O.D. range	MU IV CW Ø <sub>min.</sub> / Ø <sub>max.</sub>						
	MU IV 8/38 CW P	NA	126	16	5	96	72
	MU IV 14/38 CW P ◆	NA	96	12	5	96	72
	MU IV 19/80 CW P	NA	172	16	5	97	103
	MU IV 25/115 CW P	NA	215	16	5	101	148
	MU IV 25/128 CW P	NA	240	16	5	99	173
	MU IV 76/195 CW P	NA	410	30,5	14	158,5	208
MU IV 114/275 CW P	NA	500	30,5	14	172,5	276	
C-clamping – one shell per O.D.	MU IV 14/38 CW C	Ø 14 ÷ 38	126	16	5	79	72
	MU IV 14/38 CW C ◆	Ø 14 ÷ 38	96	12	5	79	74
	MU IV 30/58 CW C ◆	Ø 30 ÷ 58	155	12	5	88	93
	MU IV 30/80 CW C	Ø 30 ÷ 80	172	16	5	88	103
	MU IV 50/115 CW C	Ø 50 ÷ 115	215	16	5	92	148
	MU IV 50/128 CW C	Ø 50 ÷ 128	240	16	5	108	173
	MU IV 76/195 CW C	NA	410	30,5	14	178	208
	MU IV 114/275 CW C	NA	500	30,5	14	178,5	276

	MU IV AVC/OSC CW Ø <sub>min.</sub> / Ø <sub>max.</sub>	Double clamping system recommended Min. O.D. / Max. O.D.	Ø A (mm)	B (mm)	Amplitud		D (mm)	E (mm)
					Ca (mm)	Cb (mm)		
P-clamping – adjustable for the entire O.D. range	MU IV 8/38 AVC/OSC CW P	NA	142	23	20	20	150	72
	MU IV 19/80 AVC/OSC CW P	NA	200	16	20	20	136	103
	MU IV 42/115 AVC/OSC CW P	NA	235	16	20	20	139	148
	MU IV 42/128 AVC/OSC CW P	NA	340	16	20	30	134	173
	MU IV 76/195 AVC/OSC CW P	NA	410	16	20	30	165	208
	MU IV 114/275 AVC/OSC CW P	NA	530	16	20	30	179	276
SC-clamping – one shell per O.D.	MU IV 14/38 AVC/OSC CW C	Ø 8 ÷ 38	142	23	20	20	130	72
	MU IV 14/38 AVC/OSC CW C ◆	Ø 14 ÷ 38	132	35,5	20	20	130	74
	MU IV 30/51 AVC/OSC CW C ◆	Ø 30 ÷ 51	145	35,5	20	20	142	94
	MU IV 30/64 AVC/OSC CW C ◆	Ø 30 ÷ 64	158	35,5	20	20	142	94
	MU IV 30/80 AVC/OSC CW C	Ø 30 ÷ 80	200	16	20	20	126	103
	MU IV 50/115 AVC/OSC CW C	NA	235	16	20	20	128	148
	MU IV 50/128 AVC/OSC CW C	Ø 50 ÷ 128	340	16	20	30	143	173
	MU IV 76/195 AVC/OSC CW C	NA	410	16	20	30	185	208
MU IV 114/275 AVC/OSC CW C	NA	530	16	20	30	184	276	

## Options and accessories

- On board wire feeder for 1.5kg spool or external POLYFIL wire feeder for 15kg spool with wire accessories
- Clamp shells (C-clamping system) for all tube and pipe O.D.'s
- Extension cable (15m)
- Dual welding head switch box
- Compact shipping case for transport and storage
- Tungsten electrodes, pre-sharpened and pre-cut



# POLYSOUDE : Related services

## ► Guidance and technical support

A welding application specialist in your area will advise you on the welding process and appropriate equipment for your application.

## ► Commissioning / Training

A complete training program will enable you to start using the equipment immediately and in the best way possible.

## ► Maintenance / Repair

Maintenance and repair operations can be carried out at the Polysoude plant as well as on site by our service network.

## ► Rental service

Increase the flexibility of your production! A large range of equipment is available for rental from our hire fleet.

## Your partners worldwide

### ARGENTINA

**POLYSOUDE S.A.S.**  
☎ +33 (0) 2 40 68 11 00  
info@polysoude.com

### AUSTRALIA

**POLYSOUDE S.A.S.**  
☎ +33 (0) 2 40 68 11 00  
info@polysoude.com

### AUSTRIA

**POLYSOUDE AUSTRIA GmbH**  
☎ +43 (0) 3613 200 36  
austria@polysoude.at

### BELGIUM

**POLYSOUDE BENELUX**  
☎ +31 (0) 653 84 23 36  
k.meurs@polysoude.com

### POLYSOUDE BENELUX

**(SERVICE)**  
☎ +31 (0) 653 38 85 58  
h.milder@polysoude.com

### BRAZIL

**AJADE COMÉRCIO INSTALAÇÕES  
E SERVIÇOS Ltda.**  
☎ +55 (0) 11 4524 3898  
fernando@ajade.com.br

### BULGARIA

**KARWELD EOOD**  
☎ +359 (0) 29 73 32 15  
Karweld@bg400.bg

### CANADA

**MAG Tool – West**  
EDMONTON – ALBERTA  
☎ +1 800 661 9983  
magtool@magtool.com

### MAG Tool – East

TORONTO – ONTARIO  
☎ +1 905 699 – 5016  
ray@magtool.com

### CHINA

**POLYSOUDE SHANGHAI CO. Ltd**  
☎ +86 (0) 21 64 09 78 26  
jm.pan@polysoude.com.cn

### CROATIA

**EUROARC D.O.O.**  
☎ +385 (0) 1 2 40 60 77  
euroarc@euroarc.hr

### CZECH REPUBLIC

**POLYSOUDE CZ**  
☎ +420 602 60 28 55  
m.matousek@polysoude.cz

### DENMARK

**HALL & CO. INDUSTRI**  
☎ +45 (0) 39 56 06 76  
p.lorenzen@polysoude.com

### EGYPT

**POLYSOUDE UK**  
☎ +44 (0) 1942 820 935  
info@polysoude.com

### ESTONIA

**POLYSOUDE S.A.S.**  
☎ +33 (0) 2 40 68 11 00  
info@polysoude.com

### FINLAND

**SUOMEN TEKNOHAUS OY**  
☎ +358 (0) 927 47 2 10  
info@teknohaus.fi

### FRANCE

**POLYSOUDE S.A.S.**  
☎ +33 (0) 2 40 68 11 00  
info@polysoude.com

### GERMANY

**POLYSOUDE DEUTSCHLAND GmbH  
DUSSLINGEN**  
☎ +49 (0) 7072 60076 0  
info@polysoude.de

### POLYSOUDE DEUTSCHLAND GmbH

**NIEDERLASSUNG LEVERKUSEN**  
☎ +49 (0) 2171 58 13 36  
info@polysoude.de

### ISRAEL

**POLYSOUDE S.A.S.**  
☎ +33 (0) 2 40 68 11 00  
info@polysoude.com

### ITALY

**POLYSOUDE ITALIA SRL**  
☎ +39 (0) 2 93 79 90 94  
info@polysoude.it

### JAPAN

**GMT CO Ltd – KAWASAKI**  
☎ +81 (0) 44 222 6751  
gmt@e-gmt.co.jp

### GMT CO Ltd – OSAKA

☎ +81 (0) 798 35 6751  
gmt.kansai@e-gmt.co.jp

### NEW ZEALAND

**POLYSOUDE S.A.S.**  
☎ +33 (0) 2 40 68 11 00  
info@polysoude.com

### NORWAY

**TEMA NORGE AS**  
☎ +47 (0) 51 69 25 00  
tema@tema-norge.no

### PAKISTAN

**POLYSOUDE S.A.S.**  
☎ +33 (0) 2 40 68 11 00  
info@polysoude.com

### PHILIPPINES

**POLYSOUDE S.A.S.**  
☎ +33 (0) 2 40 68 11 00  
info@polysoude.com

### SINGAPORE

**POLYSOUDE SINGAPORE OFFICE**  
☎ +65 0734 8452  
Jmpan@singnet.com.sg

### SLOVAKIA

**POLYSOUDE CZ**  
☎ +420 602 60 28 55  
m.matousek@polysoude.cz

### SOUTH AFRICA

**POLYSOUDE S.A.S.**  
☎ +33 (0) 2 40 68 11 00  
info@polysoude.com

### SOUTH KOREA

**CHEMIKO CO Ltd**  
☎ +82 (0) 2 567 5336  
chemiko@chol.com

### SPAIN

**POLYSOUDE IBERIA OFFICE**  
☎ +34 609 154 683  
la.deandres@polysoude.com

### SWEDEN

**HALL & CO. INDUSTRI**  
☎ +45 (0) 39 56 06 76  
p.lorenzen@polysoude.com

### SWITZERLAND

**POLYSOUDE (SWITZERLAND) Inc.**  
☎ +41 (0) 43 243 50 80  
contact@polysoude.ch

### TAIWAN R.O.C.

**FIRST ELITE ENT. CO. Ltd**  
☎ +886 (0) 287 97 88 99  
auto.pipe@msa.hinet.net

### THAILAND

**POLYSOUDE S.A.S.**  
☎ +33 (0) 2 40 68 11 00  
info@polysoude.com

### TURKEY

**POLYSOUDE S.A.S.**  
☎ +33 (0) 2 40 68 11 00  
info@polysoude.com

### UNITED ARAB EMIRATES

**POLYSOUDE S.A.S.**  
☎ +33 (0) 2 40 68 11 00  
info@polysoude.com

### UKRAINE

**POLYSOUDE RUSSIA**  
☎ +7 (0) 495 564 86 81  
polysoude@co.ru

### UNITED STATES

**ASTRO ARC POLYSOUDE Inc.**  
☎ +1 661 702 01 41  
sales@astroarc.com

### VENEZUELA

**ENRIVA C.A.**  
☎ +58 (0) 412 34 82 602  
enriva@cantv.net



### GREAT BRITAIN

**POLYSOUDE UK**  
☎ +44 (0) 1942 820 935  
info@polysoude.com

### GREECE

**POLYSOUDE S.A.S.**  
☎ +33 (0) 2 40 68 11 00  
info@polysoude.com

### HUNGARY

**POLYWELD Kft.**  
☎ +36 (0) 20 29 88 708  
polyweld@polyweld.hu

### INDIA

**POLYSOUDE INDIA**  
☎ +91 (0) 20 40 03 59 31  
ab.kulkarni@polysoude.in

### INDONESIA

**POLYSOUDE SINGAPORE OFFICE**  
☎ +65 0734 8452  
Jmpan@singnet.com.sg

### JORDAN

**POLYSOUDE UK**  
☎ +44 (0) 1942 820 935  
info@polysoude.com

### LATVIA

**POLYSOUDE S.A.S.**  
☎ +33 (0) 2 40 68 11 00  
info@polysoude.com

### LITHUANIA

**POLYSOUDE S.A.S.**  
☎ +33 (0) 2 40 68 11 00  
info@polysoude.com

### MALAYSIA

**POLYSOUDE SINGAPORE OFFICE**  
☎ +65 0734 8452  
Jmpan@singnet.com.sg

### NETHERLANDS

**POLYSOUDE BENELUX**  
☎ +31 (0) 653 84 23 36  
k.meurs@polysoude.com

### POLYSOUDE BENELUX

**(SERVICE)**  
☎ +31 (0) 653 38 85 58  
h.milder@polysoude.com

### POLAND

**UNIDAWELD – BEDZIN**  
☎ +48 (0) 32 267 05 54  
dariusz.szota@unidaweld.pl

### ZALCO Sp. z.o.o. – WARSZAWA

☎ +48 (0) 22 894 55 30  
mbergman@zalco.pl

### PORTUGAL

**POLYSOUDE IBERIA OFFICE**  
☎ +34 609 154 683  
la.deandres@polysoude.com

### ROMANIA

**DEBISUD S.R.L.**  
☎ +40 (0) 255 21 57 85  
office@debisud.ro

### RUSSIA + C.I.S.

**POLYSOUDE RUSSIA**  
☎ +7 495 564 86 81  
info@polysoude.ru

### SAUDI ARABIA

**ALRUQEE INDUSTRIAL  
MARKETING Co. Ltd**  
☎ +966 (0) 3857 6383  
I1Manager.Khaldoun@alruqee.com

A Member of



**POLYSOUDE**  
THE ART OF WELDING

Polysoude S.A.S.

710, Bois Briand • 2 rue Paul Beaupère • BP 41606

F - 44 316 NANTES Cedex 3

Tel : +33 (0) 2 40 68 11 00 • Fax : +33 (0) 2 40 68 11 88

www.polysoude.com • e-mail : info@polysoude.com • e-mail : info@polysoude.com



Polysoude S.A.S.

710, Bois Briand • 2 rue Paul Beaupère • BP 41606

F - 44 316 NANTES Cedex 3

Tel : +33 (0) 2 40 68 11 00 • Fax : +33 (0) 2 40 68 11 88

www.polysoude.com • e-mail : info@polysoude.com • e-mail : info@polysoude.com