



CNC Cutting Machine

MAGICUT

Robust feature / Simple operation

MAGICUT

The best all-rounder CNC for job shop and large scale production.

ProArc Magicut, compact CNC cutting machine built for 100% duty cycle cutting operation, is ideal for job shop looking to add their first piece of automated machinery. Rugged and sturdy, Magicut has the same reliability and accuracy found in all ProArc cutting systems.



CNC controller

- 15" screen
- Multi-language selection
- USB port
- Recall the last cutting point



MAGICUT

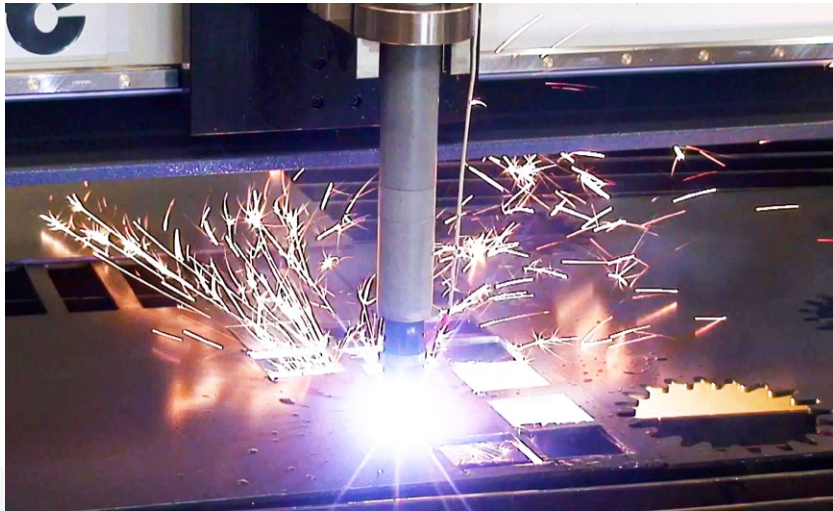

Optional accessories

- Laser Pointer
- Oxyfuel Cutting Torch:
50mm maximum material thickness
- Offline Nesting Software

OPC

THC setting panel, plasma switch and emergency stop button.



Signal Tower

Warning indication and machine fault management.



Servo motor drive

Closed loop control with constant motion torque.



Rugged structure

Solid table structure for high cutting precision.



Laser Pointer

Simple laser pointer for accurate positioning.

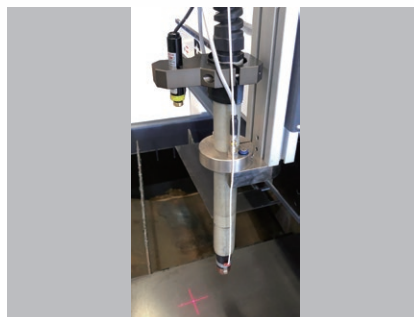

THC

Combined anti-collision, IHS and THC functions for reliable air plasma cutting .

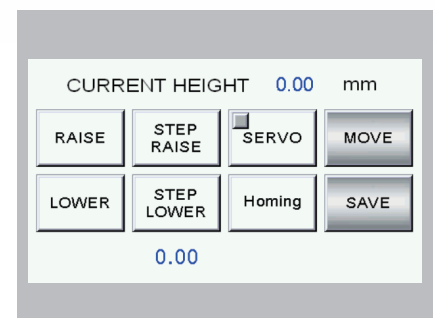

Specification

Model	Unit	Magicut 1212 (4' x 4')	Magicut 1224 (4' x 8')	Magicut 1530 (5' x 10')
Power input	~	1 Phase 200~220V 50/60 Hz, 20A		
Motor driven unit		AC Servo motor		
Travel drive method		Precision rack & Pinion		
Travel rail		Double linear roller guideway		
Overall width (A)	mm	1,850	1,850	2,250
Overall height (B)	mm	1,600	1,600	1,600
Overall length (C)	mm	2,500	3,700	4,450
Cutting width (D)	mm	1,250	1,250	1,600
Cutting length (E)	mm	1,250	2,450	3,100
Max. Cutting speed	m/min	8 (315 ipm)		
Max. Travel speed	m/min	12 (472 ipm)		
Position accuracy	mm	+/-0.1 (0.004")		
Repeatability	mm	+/-0.05 (0.002")		
Weight	Kg	750	930	1,300

Note : Other input voltage is available.

Dimensions

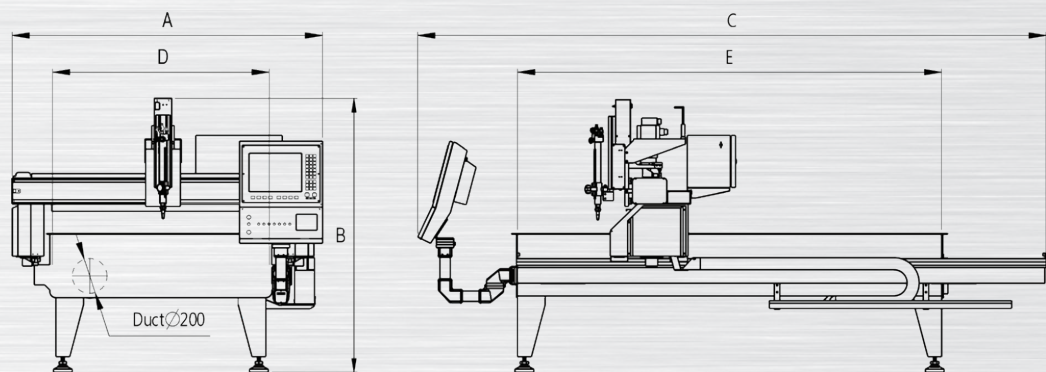

UNITED PROARC CORPORATION

No.3 Gungye 10th Road, Pingjen Industrial Park, Pingjen Dist., Taoyuan City 32459, Taiwan

Tel:886-3-4696600 Fax:886-3-4696969 E-mail:sales@proarc.com.tw

SD-4003FF