

# WS500 Manual

Software v 1.06  
Version 1.10  
Part number 91-00-32



**BRITISH  
FEDERAL**

**British Federal Ltd.,**  
Castle Mill Works,  
Birmingham New Road,  
Dudley,  
West Midlands,  
DY1 4DA

Tel: 01384 455400  
Fax: 01384 455554



## Contents

Introduction	3
Specifications	4
Connections	5
Configuring the WS500	6
Configuration Parameters	6
Programming the WS500	10
Programme parameters	11
Seam Welding Current Profiles	12
Welding with the WS500	14
Selecting a Weld Programme	14
Starting a Weld	15
Second Stage Start	15
End of Sequence Output	16
Further Functions	18
Counter	18
Cross Interlock	19
Glossary of Terms	20
British Federal International Agents	24



## Introduction

The WS500 welding control offers the reliability that ensues from simplicity. The WS500 is a compact, robust unit providing basic control for resistance welding. The membrane front panel provides a neat, water resistant finish and incorporates four push buttons and a display for programming purposes. Programming is quick and simple, as is operation of the control. Installation is also easy. The WS500 has four mounting studs and sixteen connections on a plug-in connector block.

The principle features of the WS500 are:

- Operates from 24 volt DC supply
- 50 Hz or 60 Hz operation
- 4 inputs and 4 outputs plus weld on/off
- 1 to 8 programmes, depending on mode of operation
- Configurable for:
  - Single spot
  - Repeat spot
  - Half cycle
  - Roll spot
  - Seam
- Two weld intervals and pulsation
- Retract/High lift option
- Counter with configurable lock-out
- Cross-interlock facility (2 options)
- Built-in test routines

## Specifications

Supply voltage:	24 V DC
Supply current:	< 500mA (no outputs on)
Synch. signal:	27 V AC @ 1 VA
Mains frequency:	50 or 60 Hz
Number of digital inputs:	4
Input requirement:	24 V DC, < 10mA
Number of digital outputs:	4
Digital output rating:	24 V DC, < 500mA
Pulse drive output:	5KHz, 1:10 mark/space. First pulse 24V, subsequent pulses >15V
Size:	160mm x 122mm x 35mm (50mm including connector)
Weight:	620gms

# Connections

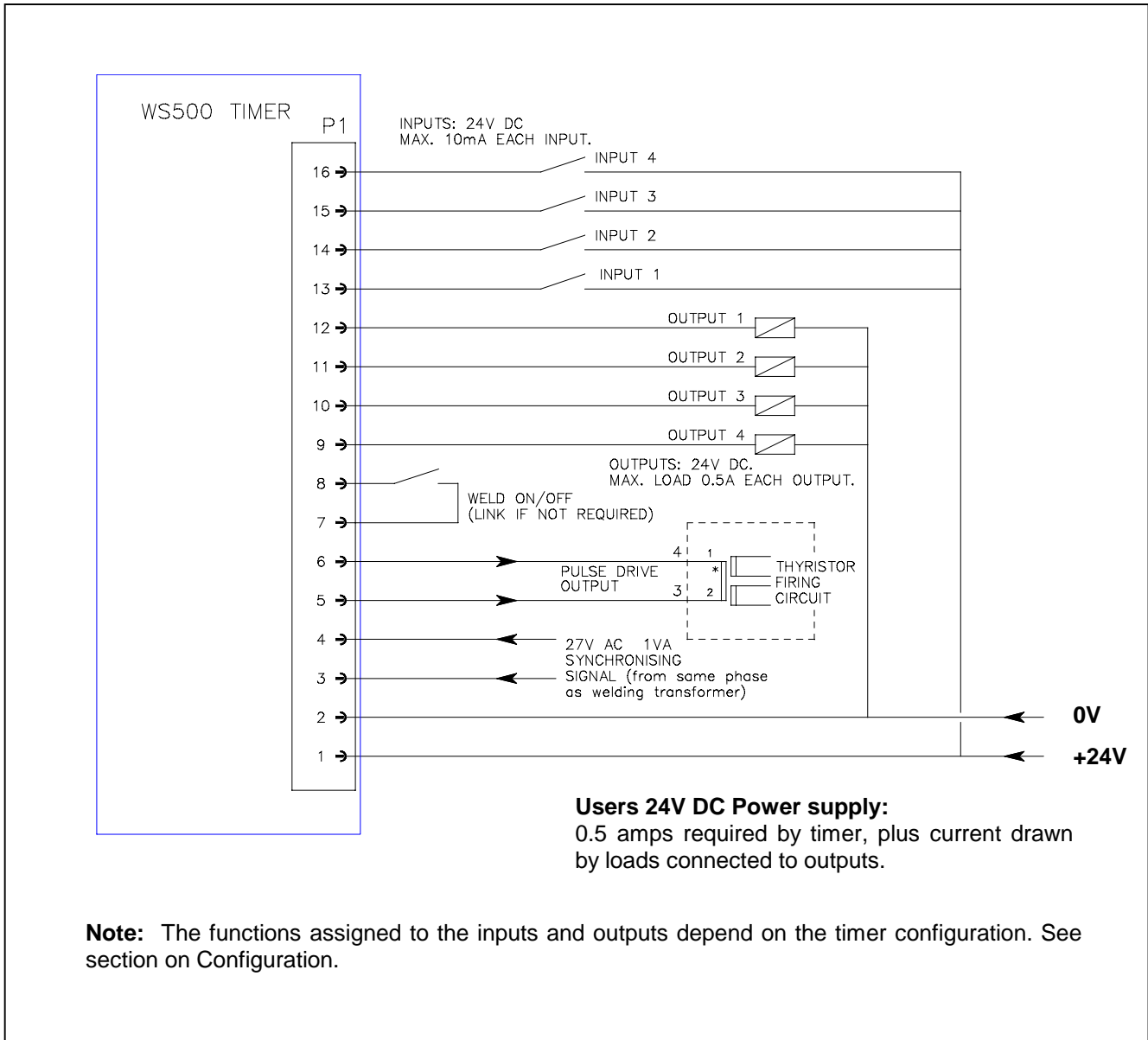

General Connection Diagram

## Configuring the WS500

The WS500 has various configurations to tailor it for specific applications.

- Press **F** until it the display reads **WS500 V1.04**
- Hold down **↩** and then press **F**. The display will read **CONFIGURE**.
- Press **↩** The display will read, for example, **CONFIG TYPE 00** This is the first item in the list of configuration parameters.
  - a) If you wish to change the parameter setting (in this case 00) use the **+** or **-** keys to make the required selection. Press **↩** to enter the value. If you do not wish to change this parameter move directly to b).
  - b) Press **↩** to move to the next item in the configuration file.
- Repeat steps a) and b) until the configuration is complete, then press **F**.

## Configuration Parameters

The items in the list of configuration parameters is shown below.

Parameter	Options
Config type	0 to 12
Retract	None Simple High Lift + High Lift -
Frequency	50 Hz or 60 Hz
Interlock	On or Off
Heat range	Low or High
X-lock type	External or Ring

### Config Type

The WS500 has 13 modes of operation, numbered as “Types” 0 to 12. Each Type offers different features, different numbers of weld programmes and may use the input and output connections in different ways. The following table gives a brief description of what each Type does, and shows the number of weld programmes available for that option.

The table should be used in conjunction with the tables of Input and Output Allocations which show how the inputs and outputs are used for each configuration Type.

Config Type	WS500 Operation	No. of weld progs.
00	<b>Spot/repeat</b> Simple spot welding with single or repeated weld sequences and no other functions.	8
01	<b>Spot/repeat with cross interlock</b> Spot welding with single or repeated weld sequences giving an interlock output to prevent other timers welding at the same time.	4



02	<b>Spot/repeat with retract</b> Spot welding with single or repeated weld sequences with an input and output for controlling the “open” and “working” positions of the welding gun.	4
03	<b>Spot/repeat with counter</b> Spot welding with single or repeated weld sequences with a counter that gives an output when the programmed number of welds has been reached.	4
04	<b>Spot/repeat with cross interlock and retract</b> Spot welding with single or repeated weld sequences giving an interlock output to prevent other timers welding at the same time, and an input and output for controlling the “open” and “working” positions of the welding gun.	2
05	<b>Spot/repeat with counter and retract</b> Spot welding with single or repeated weld sequences with a counter that gives an output when the programmed number of welds has been reached and has an input and output for controlling the “open” and “working” positions of the welding gun.	2
06	<b>Spot/repeat with counter and cross interlock</b> Spot welding with single or repeated weld sequences with a counter that gives an output when the programmed number of welds has been reached and with an interlock output to prevent other timers welding at the same time.	2
07	<b>Spot/repeat with counter, cross interlock and retract</b> Spot welding with single or repeated weld sequences with a counter that gives an output when the programmed number of welds has been reached, also an interlock output to prevent other timers welding at the same time and with an input and output for controlling the “open” and “working” positions of the welding gun.	1
08	<b>Half cycle</b> Spot welding using only a half cycle of weld time.	8
09	<b>Half cycle with cross interlock</b> Spot welding using only a half cycle of weld time and giving an interlock output to prevent other timers welding at the same time.	4
10	<b>Half cycle with counter</b> Spot welding using only a half cycle of weld time also with a counter that gives an output when the programmed number of welds has been reached..	4
11	<b>Roll-spot</b> Spot welding with an output to operate motor-driven welding wheels during the OFF time between weld sequences.	8
12	<b>Seam</b> Uses seam wheels, a motor drive and continuous, or modulated current, to provide a seam weld.	8

## Input Allocations

Config Type	Input 1 (Pin 13)	Input 2 (Pin 14)	Input 3 (Pin 15)	Input 4 (Pin 16)
0	Start	Prog. sel. bit 1	Prog. sel. bit 2	Prog. sel. bit 4
1	Start	Prog. sel. bit 1	Prog. sel. bit 2	2 <sup>no</sup> stage
2	Start	Prog. sel. bit 1	Prog. sel. bit 2	Retract
3	Start	Prog. sel. bit 1	Prog. sel. bit 2	Count reset
4	Start	Prog. sel. bit 1	Retract	2 <sup>no</sup> stage
5	Start	Prog. sel. bit 1	Count reset	Retract
6	Start	Prog. sel. bit 1	Count reset	2 <sup>no</sup> stage
7	Start	Retract	Count reset	2 <sup>no</sup> stage
8	Start	Prog. sel. bit 1	Prog. sel. bit 2	Prog. sel. bit 4
9	Start	Prog. sel. bit 1	Prog. sel. bit 2	2 <sup>no</sup> stage
10	Start	Prog. sel. bit 1	Prog. sel. bit 2	Count reset
11	Start	Prog. sel. bit 1	Prog. sel. bit 2	Prog. sel. bit 4
12	Start	Prog. sel. bit 1	Prog. sel. bit 2	Prog. sel. bit 4

## Output Allocations

Config Type	Output 1 (Pin 12)	Output 2 (Pin 11)	Output 3 (Pin 10)	Output 4 (Pin 9)
0	Weld air valve	End of sequence	Not used	Not used
1	Weld air valve	End of sequence	Interlock	Not used
2	Weld air valve	End of sequence	Not used	Retract
3	Weld air valve	End of sequence	Counter	Not used
4	Weld air valve	End of sequence	Interlock	Retract
5	Weld air valve	End of sequence	Counter	Retract
6	Weld air valve	End of sequence	Counter	Interlock
7	Weld air valve	Interlock	Counter	Retract
8	Weld air valve	End of sequence	Not used	Not used
9	Weld air valve	End of sequence	Interlock	Not used
10	Weld air valve	End of sequence	Counter	Not used
11	Weld air valve	Motor	Not used	Not used
12	Weld air valve	Motor	Not used	Not used

## Retract

Some operational modes provide a Retract facility. This feature is used when a welding gun has two “open” states, a wide open state for positioning the gun around a component, and a working state.

There are three modes of Retract operation:

- Simple Retract**      The Retract Output directly mimics the Retract Input. The Retract Output must be off for welding to proceed. If the Retract Output is on the display will read “Retract not ready”.
- Hi Lift +**              With this mode of retract, an impulse on the Retract Input changes the state of the Retract Output. In this case the Retract Output must be on for welding to take place. If the Retract output is off, the display will read, “Retract not ready”.

**Hi Lift -**

With this mode of retract, an impulse on the Retract Input changes the state of the Retract Output. In this case the Retract Output must be off for welding to take place. If the Retract output is on, the display will read, "Retract not ready".

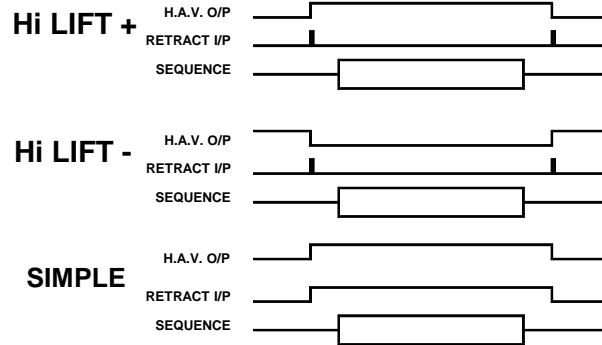

**Frequency**

Select frequency of mains supply.

**Interlock**

Select Interlock ON for machines where the electrodes are controlled by the WS500's weld air valve output. In this mode, when a weld sequence has progressed beyond the Squeeze time, the sequence continues to completion, regardless of the Start signal.

Select Interlock OFF for machines with no weld air valve, such as pedal spot welders and poke welders. In this mode, the weld sequence is terminated if the Start signal is removed before the sequence has completed.

**Heat Range**

Select Heat Range High for hotter heat settings. The use of this setting may result in "dead angle" at higher heats. (After a certain point, increasing the heat no longer increases the current).

Select Heat Range Low for cooler heat settings. This should be used if low heat levels in the "High" setting, produce too much current.

**X-Interlock type**

Select EXT if you are using an external cross-interlock unit.

Select RING if you have wired the WS500 for ring type cross-interlocking

See the section on cross-interlocking for a full explanation.

## Programming the WS500

To programme the WS500 press the **F** key until the display reads **EDIT PROGRAM 0**

Use the **+** or **-** key to select the programme required. The display will flash. Press **↩** to enter the programme number. Press **↩** again to move the programmer to the

first parameter. With each parameter use the **+** and **-** keys to select the value, or type. This will cause the display to flash. When the value is correct enter it by pressing **↩**

Then press **↩** again to move onto the next parameter. At any point **F** can be pressed to exit programming weld parameters. If the WS500 is in a mode that uses a counter, the display will read **COUNTER**. This is programmed in the same way.

The table below shows the welding parameters and the order in which they appear. It should be noted that not all parameters are used in every mode.

Parameter		
Programmes	Range of values	Applicable Config. Modes
Mode	Single or Repeat	0 – 7
Heat 1	0 – 99	0 – 12
Heat 2	0 – 99	0 – 7, 11 - 12
Presqueeze	0 – 99	0 – 7, 11 - 12
Squeeze	0 – 99	0 – 12
Weld 1	0 – 99	0 – 7, 11 - 12
Cool 1	0 – 99	0 – 7, 11 - 12
Weld 2	0 – 99	0 – 7, 11 - 12
Cool 2	0 – 99	0 – 7, 11 - 12
Pulses	1 – 9	0 – 7, 11
Hold	0 – 99	0 - 12
Balance	0 - 60	12
Off	0 – 99	0 – 7, 11
<b>Counter</b>		
Counter now	0 – 9999	3, 5 – 7, 10
End count	0 – 9999	3, 5 – 7, 10
Stop at end	Stop at end/Continue at end	3, 5 – 7, 10

## Programme parameters

<b>Mode</b>	Selects either Single Sequence or Repeat Sequence operation. Single Sequence operation performs one weld sequence when the timer is initiated. Repeat Sequence performs successive weld sequences for the duration of the Start signal.
<b>Heat 1</b>	Controls the heat of the first weld interval.
<b>Heat 2</b>	Controls the heat of the second weld interval.
<b>Presqueeze</b>	The time (in cycles) allowed for the electrodes to meet.
<b>Squeeze</b>	The time (in cycles) allowed for the electrodes to build up full welding pressure on the component.
<b>Weld 1</b>	The duration (in cycles) of the first weld interval.
<b>Cool 1</b>	The time (in cycles) between the first and second weld intervals.
<b>Weld 2</b>	The duration (in cycles) of the second weld interval.
<b>Cool 2</b>	(Only applicable when using pulsations) The time (in cycles) between pulses of Weld 2.
<b>Pulses</b>	The number of times pulses of Weld 2.
<b>Hold</b>	The time (in cycles) for which welding pressure is maintained on the weld after welding current has ceased.
<b>Balance</b>	(Seam mode only) Adjusts the heat of the first half cycle of weld in a seam weld. The adjustment range is 0 to 60. A nominal setting for this is 45. To set it using a weld current meter, measure the current of the +ve half cycles, and the current of the -ve half cycles, then adjust the Balance to get the two readings to be the same. (The "grunt" from the transformer sounds smooth and even for a balanced weld.)
<b>Off</b>	(Only applicable in Repeat mode). The time (in cycles) between successive weld sequences.
<b>Count Now</b>	The number of weld sequences carried out since the counter was reset.
<b>End Count</b>	The number of welds after which the timer will switch on the Counter Output.
<b>Stop/Continue at End</b>	Selects whether or not the timer will initiate further weld sequences when the Counter Output has switched on.

## Seam Welding Current Profiles

In seam welding mode (Configuration mode 12) there are two weld pulses and two cool times available. These can be used to give a number of weld current profiles, as shown below.

### Seam Continuous

Example settings:

Weld 1 = 10  
 Cool 1 = 0  
 Weld 2 = 0  
 Cool 2 = 0  
 Heat 1 = 40  
 Heat 2 = 0

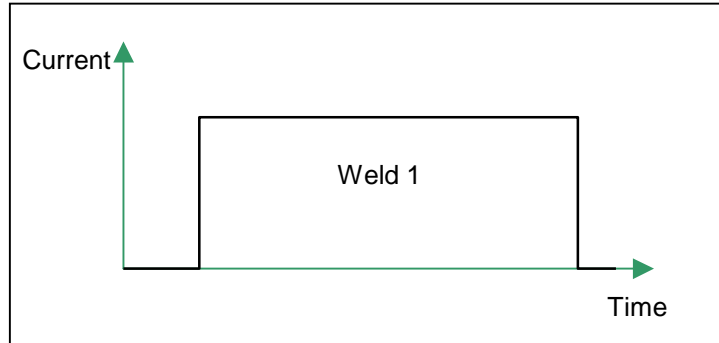

### Seam Pulsation

Example settings:

Weld 1 = 10  
 Cool 1 = 5  
 Weld 2 = 0  
 Cool 2 = 0  
 Heat 1 = 40  
 Heat 2 = 0

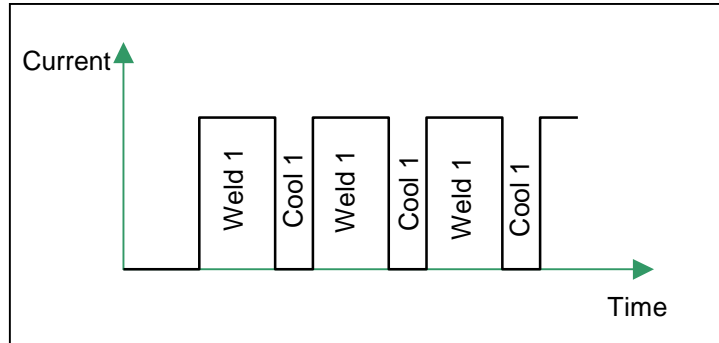

### Seam Modulation

Example settings:

Weld 1 = 10  
 Cool 1 = 5  
 Weld 2 = 10  
 Cool 2 = 5  
 Heat 1 = 30  
 Heat 2 = 70

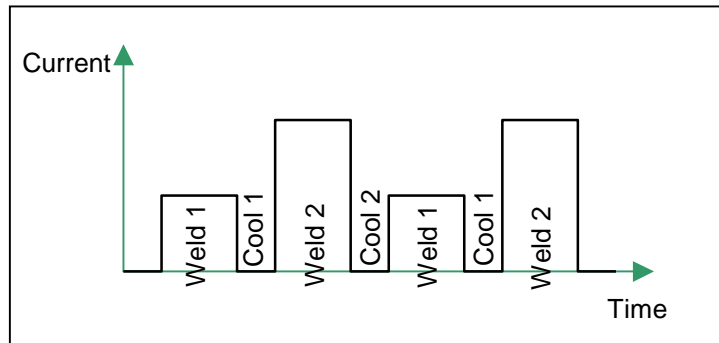

Example settings:

Weld 1 = 10  
 Cool 1 = 0  
 Weld 2 = 10  
 Cool 2 = 5  
 Heat 1 = 30  
 Heat 2 = 70

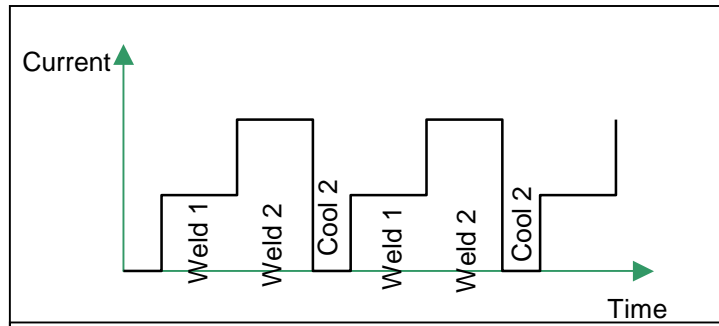

Example settings:

Weld 1 = 10  
 Cool 1 = 0  
 Weld 2 = 10  
 Cool 2 = 0  
 Heat 1 = 30  
 Heat 2 = 70

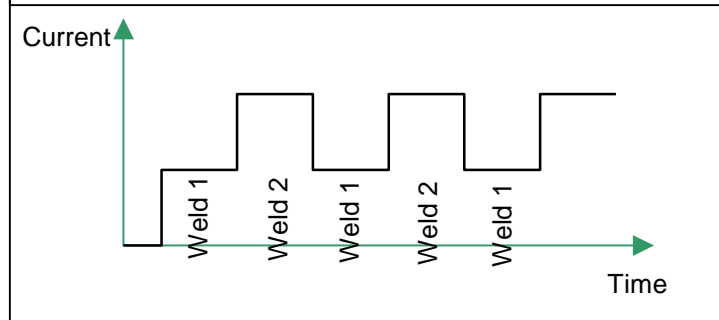

## Welding with the WS500

To weld, the WS500 needs to have been configured for your specific application. (See section on “Configuration”). Having been configured, the timer must be programmed with the weld parameters for the job in hand. Several sets of weld parameters can be held in the WS500. Each set of parameters is called a “Programme”. (See section “Programming the WS500”).

### Selecting a Weld Programme

#### Using Inputs

Refer to the timer connection drawing and the tables below.

#### For software versions v1.03 and higher

If WS500 has software version v1.03 or higher, external programme selection must be selected.

Press  until the WS500 displays READY.

Press . The display will show either a programme number or External Select.. If the timer

does not show External Select press  until it does, then press .

With the timer displaying External Select, press  to return to normal mode.

Depending on which configuration mode the timer is using, there can be 1, 2, 4 or 8 programmes available. The following tables show how to select programmes for each mode of configuration.

0 on an input means 0v present on input pin.  
1 on an input means 24v present on an input.

#### Mode 7

Only operates on programme 0. No selection necessary.

#### Modes 4, 5 and 6

Prog. No.	Input 2
0	0
1	1

#### Modes 1, 2, 3, 9 and 10

Prog. No.	Input 2	Input 3
0	0	0
1	1	0
2	0	1
3	1	1





**Modes 0, 8, 11 and 12**



Prog. No.	Input 2	Input 3	Input 4
0	0	0	0
1	1	0	0
2	0	1	0
3	1	1	0
4	0	0	1
5	1	0	1
6	0	1	1
7	1	1	1

**Using timer keypad**

(only applicable to software versions v1.03 and higher)

Press  until the WS500 displays READY.

Press . The display will show either a programme number or External Select.

Press either  or  to get the required programme number, then press .

Press  to return to normal mode.

When the timer is initiated, it will weld using the programme selected by the previous operation, not a programme selected by inputs.

**Starting a Weld**

When the timer has been configured and programmed, welding can proceed. Select the programme to be used (see previous section) and operate the Start input (input 1). A weld sequence will begin.

The Start signal must be held on until the first weld period. If the Start signal is removed before this, the weld sequence will be aborted.

**Second Stage Start**

(Applicable only to modes 1, 4,6,7 and 9)

Some modes require a Second Stage Start. Where this is needed the timer checks input 4 when the weld sequence has reached the end of the Squeeze time. If the input has 24v on it, the sequence continues. If there is no voltage present on input 4, the sequence waits for the signal.

### End of Sequence Output

(Applicable to all modes except 7, 11 and 12)

In Single Spot operation, at the end of the weld sequence the End of Sequence output switches on. If the Start signal is still present, the End of Sequence signal remains on until the Start signal is removed.

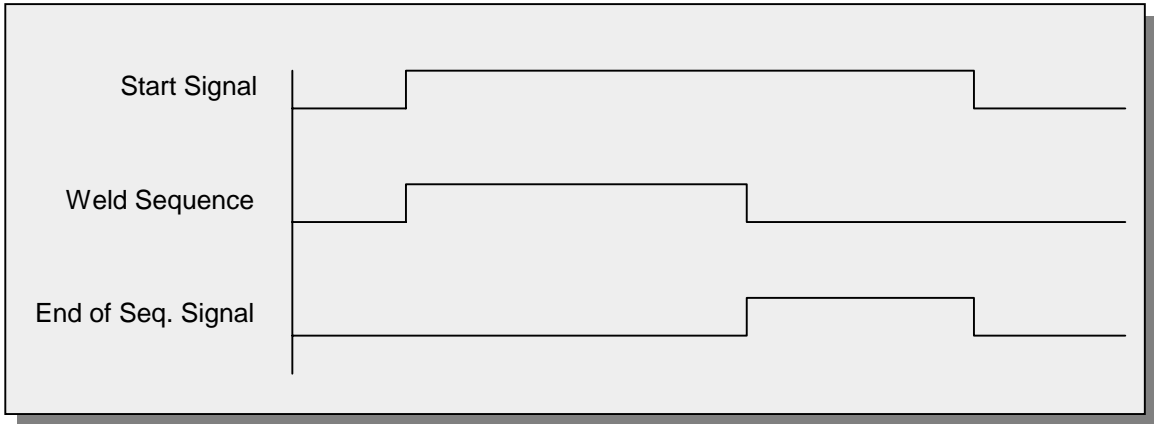

In Single Spot operation, at the end of the weld sequence the End of Sequence output switches on. If the Start signal is absent, the End of Sequence signal switches on for a time programmed as EOS Duration in the timer configuration.

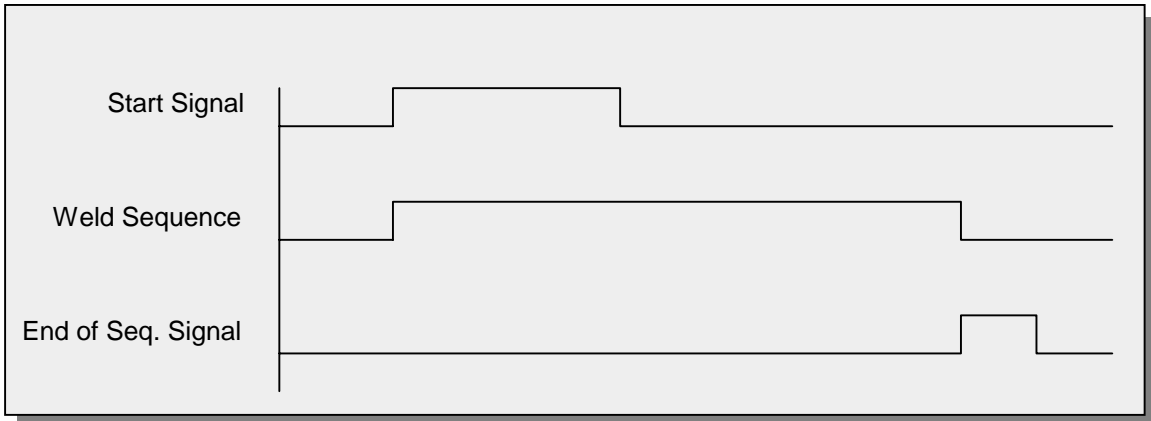

In Repeat Spot operation the End of Sequence output switches on for the Off time between sequences, and for the time entered in the timer configuration as EOS Duration, after the final sequence.

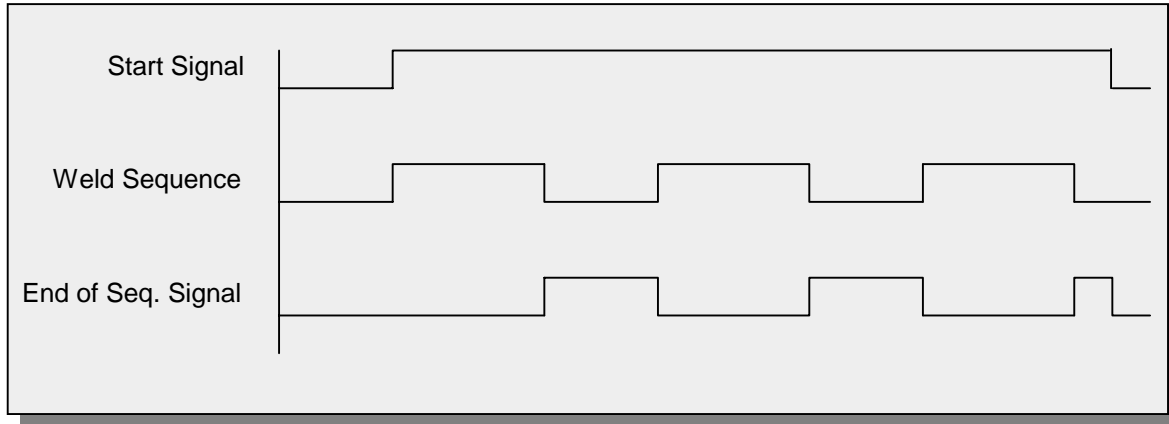

## Further Functions

### Counter

Certain modes of operation provide a counter facility. In this an "End Count" value is programmed into the WS500. A counter within the WS500 increments each time a weld sequence is completed. When the number of welds completed equals the number of welds programmed as "End Count" the Count Output switches on.

If "Stop at End" has been programmed, the WS500 will ignore Start inputs when this stage has been reached. If "Continue at End" has been programmed, welding will continue.

The counter and the Count Output can be cleared by applying a signal to the Reset input.

At any stage the progress of the counter can be observed, and changed if required. This is the value "Count Now", found in the programming section.

## Cross Interlock

A cross interlock is an arrangement of welding controls that ensures no more than one control is welding at any time. This is to ensure that the mains supply is not over-loaded.

WS500 offers a choice of two cross-interlocking schemes, called EXTERNAL and RING.

### EXTERNAL cross-interlock.

This option requires an external cross-interlock unit. Interlocking is achieved by the Cross Interlock output from the timer switching on at the end of squeeze time and switching off at the beginning of the Hold time. Cross Interlock outputs from a number of timers are connected to the Cross Interlock Unit. This grants welding permission to one timer at a time by controlling the Second Stage Start inputs of the timers. The cross-interlock unit requires one channel for each connected timer.

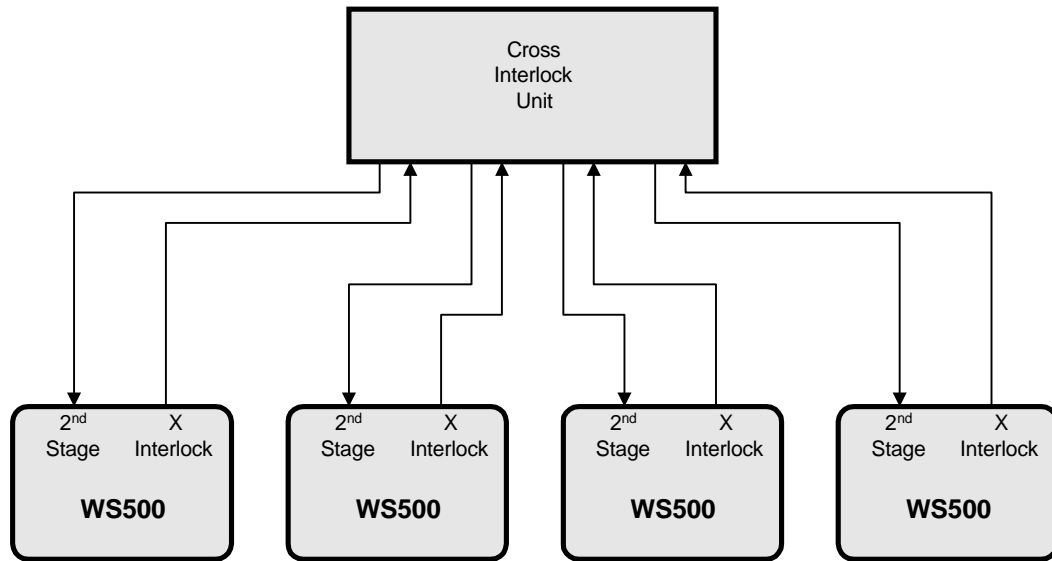

### RING cross-interlock.

This option requires no external hardware. Timers are simply wired in a ring configuration, with the cross interlock output from one timer feeding the second stage input of the next timer. Any number of timers may be connected in this way. Interlocking is achieved by an internal protocol which grants welding permission to one timer at a time.

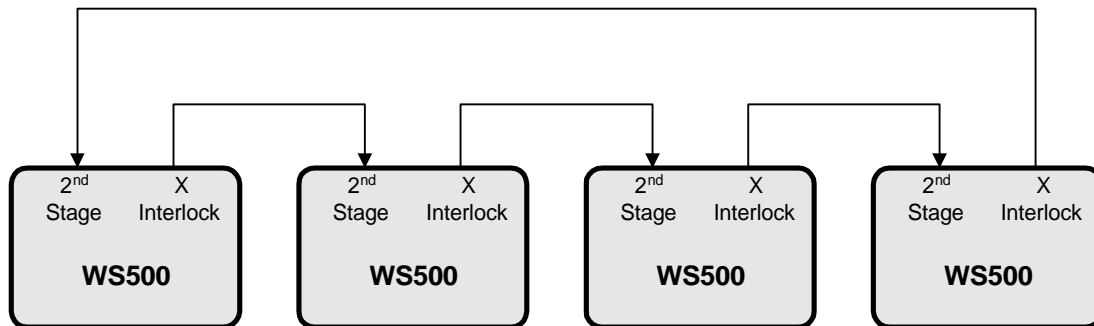

## Glossary of Terms

AVC	Automatic Voltage Compensation
CCR	Constant current regulation. See Constant Current
Const I	Constant current
Constant current	Closed loop control of weld current resulting in weld current being regulated to a programmed value. The current achieved by this method of control is independent of external influences.
ControlNet	A network for controlling a number devices (a device could be a weld timer).
Cool	The time interval, in a weld sequence, between applications of current.
Cool 1	The time period, within a weld sequence, between the end of Weld 1 pulse and the start of Weld 2 pulse.
Cool 2	The time period, within a weld sequence, between successive applications of the Weld 2 pulse (pulsations).
Cool 3	The time period, within a weld sequence, between the end of Weld 2 pulse and the start of Weld 3 pulse.
Cool time	A period of time, in a weld sequence, between applications of current. – Expressed in mains cycles.
CT	Current transformer
Current transformer	A coil of wire wound on a circular core. This is used to measure the current in a wire passing through the circular core. The weld timer  uses this to measure primary current.
DeviceNet	A network for controlling a number stations (a station could be a weld timer).
Downslope	A linear decrease in current from the welding value to a final value, applied to the main weld pulse (Weld 2).
Downslope time	Time taken for current to decrease from the welding value to a final value. – Expressed in mains cycles.
End of sequence	An output that switches on as the electrodes open on completion of a weld. The output indicates completion of the weld sequence.
EOS	End of sequence.
Ethernet	A network for programming a number devices (a device could be a weld timer).
Fieldbus control	General term for control of timers over a network.
Heat	A measure of power put into a phase angle controlled (non- constant current) weld. The Heat relates directly to the firing angle in electrical degrees, on the mains voltage waveform. – Expressed as a percentage.
Heat 1	% Heat set for weld interval 1 (Weld interval 1 is sometimes referred to as “preheat”).
Heat 2	% Heat set for weld interval 2. Weld interval 2 is usually programmed to provide the actual weld, unlike weld 1 – preheat, and weld 2 – post heat.
Heat 3	% Heat set for weld interval 3 (Weld interval 3 is sometimes referred to as “post heat”).
Heat stepping	See Stepping.
Hold	The time, in a weld sequence, between the last application of

		current and the electrodes opening. This time allows the molten material created by the weld process, to solidify.
Hold time		The time period following the last weld pulse, prior to the electrodes opening. This period allows the molten material to solidify. – Expressed in mains cycles.
Hub		A component used with the Ethernet network for connecting a number of devices such that all data appears on all parts of the network.
I.P. address		Internet Protocol Address. A unique address used by devices on an Ethernet network.
IGBT		Insulated Gate Bipolar Transistor. A type of power transistor used in inverters.
Initiation signal		The signal that starts the weld sequence.
Interbus S		A network for controlling a number stations (a station could be a weld timer).
Inverter		See Medium Frequency Inverter
kA		Kilo amp. 1000 amps
KSR		German initials for constant current.
kVA		Unit of power. 1000 volt amps
LED		(Light Emitting Diode) An indicator that gives light when energised. There are different coloured types and some types can change colour.
mA		Milli-amp 1/1000 amp
Medium Inverter	Frequency	A piece of equipment for powering a Medium Frequency welding transformer.
Medium welding	frequency	System of welding using 1000 Hz or 1200 Hz instead of mains frequency.
MF		Medium frequency (welding)
mV		Milli-volt 1/1000 volt
Network adapter		An interface card for a computer giving it access to an Ethernet connection.
Off time		In a Repeated weld sequence, this is the time between sequences. – Expressed in mains cycles.
PC		Personal computer
PHA		Phase angle control.
Phase angle control		Open loop control of weld current using Heat setting. This method does not use Constant Current and the current achieved can be influenced by external parameters such as mains voltage, cable lengths, etc..
Ping		A diagnostic programme that tests if a station on an Ethernet network is responding.
Post heat		The application of current to prevent the weld (carried out by Weld 2) cooling too quickly. Sometimes called “Weld 3”.
Pre heat		The application of current, in preparation for the actual weld current. This application of current is intended to burn through the plating or surface contamination of the work piece. Sometimes call “Weld 1”.
Presqueeze		The time interval in a weld sequence for the electrodes to close onto the work piece.
Presqueeze time		The time allowed for the welding electrodes to close onto the components to be welded. – Expressed in mains cycles.
Primary current		The current in the primary winding of the weld transformer. – The current drawn from the mains whilst welding.
Profibus DP		A network for controlling a number devices (a device could be a weld timer).
Profibus FMS		A network for programming a number devices (a device could be a

	weld timer).
Prog Sel	See Programme Select i/p
Programme Select I/P	An input, usually one of several, giving a binary number to select the weld programme to be used.
Proportional valve	A device for regulating air-line pressure. Controlled by 0 – 10 v DC or 4 – 20 mA analogue signal.
Pulsations	The number of times the main weld interval (Weld 2) is applied. Successive applications of Weld 2 are separated by a Cool time.
Pulse Drive O/P	Timer output for driving thyristor firing circuit.
Retract	A system whereby the electrodes have two open positions: - Fully open to move the weld gun to and from the work piece, and an intermediate working position, for normal welding.
Retract air valve	For use on a gun where the electrodes can be opened and closed in two stages. This is an electrically controlled valve for admitting air to the air cylinder responsible for first stage of closing of the electrodes.
RS232	Serial communication system suitable only for short cables. This is the type of connection made via a COM socket on a computer.
Second Stage Initiation	A signal required to allow the weld sequence to proceed from the end of the Squeeze time to the beginning of the Weld interval. If the timer requires this signal, and it is absent, the sequence is halted until the signal is given. This input may be used to check electrode force has reached the correct value, or to make the sequence wait until another machine has finished it's weld.
Second Stage Start	See Second Stage Initiation
Secondary current	The current in the secondary winding of the weld transformer. – The weld current.
Squeeze	The time interval in a weld sequence for the electrodes to exert full welding force on the work piece.
Squeeze time	The time allowed for the welding electrodes to build up full pressure on the components to be welded. – Expressed in mains cycles.
Start 1	The signal that starts the weld sequence on Gun 1.
Start 2	The signal that starts the weld sequence on Gun 2.
Start signal	The signal that starts the weld sequence.
Stepper	A programme of parameters required for stepping.
Stepping	A technique of progressively increasing the weld current over the course of a large number of welds in order to compensate for the effects of electrode wear.
Switch	An Ethernet device for connecting other Ethernet devices together having the ability to direct packets of data to a specific destinations rather than the whole network.
Synchronisation	The actions of the weld timer are synchronised to the zero – voltage crossing points of the mains.
Thermostat	A switch device that operates at a certain temperature.
Thyristor	High power switch used for switching the mains supply to the weld transformer. Thyristors are controlled by a pulse drive.
Tip dress acknowledge	An input to a weld timer acknowledging that the electrodes have been dressed.
Tip dress request	An output given by a weld timer to indicate that the electrodes require dressing.
Tip dressing	Filing or machining worn electrodes to restore their original shape and dimensions. An adaptation of a Stepper to facilitate automatic dressing of electrodes.
Toroid	A device used for sensing current in a cable. The current carrying



---

	cable must pass through the toroid.
Upslope	A linear increase in current from an initial value to the welding value, applied to the main weld pulse (Weld 2).
Upslope time	Time taken for current to increase from an initial value to the welding value. – Expressed in mains cycles.
VA	Volt amp
WAV	Weld air valve.
Weld 1	A weld pulse intended to burn through surface coatings in preparation for the next weld pulse which will actually weld the components. Sometimes called Pre Heat. – Expressed in mains cycles.
Weld 2	The weld pulse that welds the components together. – Expressed in mains cycles.
Weld 3	A weld pulse following the pulse that welded the components together, included to slow the rate of cooling of the weld, sometimes called Post Heat. – Expressed in mains cycles.
Weld air valve	Electrically controlled valve for admitting air to the air cylinder responsible for forcing the weld electrodes together.
Weld current	High current passed from one electrode to the other, through the components being welded. The current must be large enough to generate sufficient heat to melt the metal and produce a weld.
Weld Transformer	Electrical component for converting mains voltage input to low voltage, welding current output.

## British Federal International Agents

<b>Brazil</b> (Fransisco Seminara)	<b>Fransisco Seminara</b> Manuel Belzu 2769 CP 1636 – Olivos Buenos Aires Argentina.	Tel: 00 54 11 47950832 Fax: 00 54 11 47965361
<b>Chile</b> (Oscar Toro)	<b>Remi Ltda</b> Casilla 625, Chileo 1485 Santiago, Chile	Tel: 00 562 556 9025 Tlx: 245654 REMI Fax: 00 562 555 2585
<b>China</b> (Cindy Zhang)	<b>British Federal Beijing</b> c/o CBTG Office Floor 2, 31 Technical Club 15 Guanghua Li Jianguomenwai Beijing 100020 P R China	Tel: 00 86 10 659311/2/3 Fax: 00 86 10 65936610 Email: bfb@ht.rol.cn.net
<b>Denmark</b> (Bertil Johnsson)	<b>R-C Industrieteleknik</b> N. Industrigatan 29 S-314 31 Hyltebruk, Sweden	Tel: 00 46 345 10646 Fax: 00 46 345 17074 Car phone: 10 249 1323 Email: rcibj@algonet.se
<b>Egypt</b> (Reda Foty)	<b>Intermass</b> 13, Mahmoud Bassiouni Street 11111 Kasr El Nil., Cairo, Egypt	Tel: 00 202 578 0815 TLX: 21671 MTAT UN Fax: 00 202 578 3177
<b>Finland</b> (Bertil Johnsson)	<b>R-C Industrieteleknik</b> N. Industrigatan 29 S-314 31 Hyltebruk, Sweden	Tel: 00 46 345 10646 Fax: 00 46 345 17074 Car phone: 10 249 1323 Email: rcibj@algonet.se
<b>Germany</b> (Götz & Mark Burkhardt)	<b>Burkhardt Industrieteleknik</b> Falkenweg 4 65606 Villmar Germany	Tel: 00 49 6482 941500 (sales) 00 49 6482 941501 (service) Fax: 00 49 6482 5688
<b>Greece</b> (Tassos Koublis)	<b>Tassos Koublis</b> 15A Xenophontos Street Athens 118, Greece	Tel: 00 301 323 6131 Tlx: 219239 LEKA GR Fax: 00 301 653 6929
	Interklima:	Tel: 00 301 653 6922/651 2895 Tlx: 221599 INTE GR
<b>India</b> (Deepak Krishnankutty)	<b>Verson Internatinal India</b> Flat D 'Eden Rock' Yellappa Chetty Layout 37 Ulsoor Road	Tel: 00 91 80 558 6890 Fax: 00 91 80 558 8284

	Bangalore 560 042 India	
<b>Indonesia</b> (Tan Hean Margaret Tan)	<b>Industrial Power Eng Sdn Bhd</b> & 16 Jalan SS4/17 47301 Petaling Jaya Selangor, Malaysia	Tel: 00603 7747 109 Tlx: RS 37738 PMBELA Fax: 00 603 7765 105 Cables: INPOW Home: 00 603 7184 115 Car phone: 011 3462 07
<b>Iran</b> (Mrs. P. Ford)	<b>Martin Electric Mfg Ltd</b> Poplars Place, Turners Hill Road, Cophorne, West Sussex, RH10 4HH	Tel: 01342 713280 Tlx: 957320 TELXUS G Fax: 01342 713666
	<b>Iran Welding Industries Ltd</b> 335/337, 3rd Floor Sakhteman Aluminium Jomhuri Street, Tehran, Iran	Tel: 00 9821 671 947 Tlx: 213636 TPBA IR Fax: 00 9821 488 3568
<b>Israel</b>	<b>Adler &amp; Stern Ltd</b> Hamistadeut 206, Haifa Bay Haifa 31014, Israel	Tel: 00 972 441 3859/8630 Tlx: 46400 4 ADLERSTERN 8041
	Mail Address: PO Box 1539, 31000 Haifa, Israel	
<b>Italy</b> (Atilio Alessio)	<b>Alessio</b> Via Urbano Rattazzi 14 15025 Morano sul po (Al) Italy	Tel: 00 39 141 85605/85488 Fax: 00 39 142 85607 Email: atales@tin.it
<b>Korea</b> <b>Republic of South</b> <b>Korea</b> (David Kim)	<b>Jin 'A' Commerce &amp; Co</b> 132-4, Bangwha 3Dong Kangsu-hu, Seoul Republic of South Korea	Tel: 00 822 666 1133 Tlx: K23413 PANWELD Fax: 00 822 666 1441/2 Email: jinacom@interpia.net
<b>Malaysia</b> (Tan Hean Margaret Tan)	<b>Industrial Power Eng Sdn Bhd</b> 16 Jalan SS4/17 47301 Petaling Jaya Selangor, Malaysia	Tel: 00603 7747 109 Tlx: RS 37738 PMBELA Fax: 00 603 7765 105 Cables: INPOW Home: 00 603 7184 115 Car phone: 011 3462 07
<b>Mexico</b> (José Maria Blix)	<b>British Federal Mexico, S.A. de</b> <b>C.V.</b> Av. Toluca # 373-M Col. Olivar de Los Padres Mexico, D.F. 01780 Mexico	Tel: 00 525 668 3915 Fax: 00 525 668 2598 Email: jmblix@cs.com

<b>Monterrey</b> (Enrique Michelena)		Tel: 00 528 347 8626 Fax: 00 528 346 5009
<b>New Zealand</b>	<b>BOC New Zealand Industrial Gases Ltd.</b> 21-27 Epsom Road Christchurch, New Zealand	Tel: 00 643 348 7199 Fax: 00 643 343 0463
<b>Northern Ireland</b> (Brian Watson Andy Hyslop)	<b>Modern Tool (Industrial Supplies) Ltd</b> 289, Shore Road, Belfast, BT15 3PW, N. Ireland	Tel: 01232 771188 Fax: 01232 774111
<b>Peru</b> (Emilio Navarro)	<b>Soldaduras Andinas SA</b> Apartado Correo 1957 Lima, Peru	Tel: 00 511 474 2758 Fax: 00 511 474 4501/0967 Cables: Solandina
	Mail Address: SkywayUSA Mail, Box Centre 7225 NW 25 St, Suite 100 Box 044, Miami, Florida 33122, USA	
<b>Philippines</b> (Peter Lee)	<b>Mesco</b> PO Box 468 Makati Metro Manila 1299 Philippines	Tel: 00 632 673 4301-5/631 3767 Tlx: 43107/42267 Fax: 00632 631 4028 Home Tel: 00632 810 7945/47 Home Fax: 00 632 810 2978
<b>Singapore</b> (Tan Hean Margaret Tan)	<b>Industrial Power Eng Sdn Bhd</b> 16 Jalan SS4/17 47301 Petaling Jaya Selangor, Malaysia	Tel: 00603 7747 109 Tlx: RS 37738 PMBELA Fax: 00 603 7765 105 Cables: INPOW Home: 00 603 7184 115 Car phone: 011 3462 07
<b>South Africa</b> (Ian Barkhuizen)	<b>B.F.South Africa</b> PO Box 67202 Bryanston 2021 South Africa	Tel: 00 27 11 702 2000 Fax: 00 27 11 468 3098 Mobile: 00 27 83 305 5050
(Tony Mulhearn)	<b>B.F.South Africa</b> African Timbers Complex Haupt Street Sidwell Port Elizabeth 6001 South Africa	Tel: 00 27 41 41 2689 Fax: 00 27 41 41 2680 Mobile: 00 27 83 25 26 381

**Sweden**  
(Bertil Johnsson)

**R-C Industri Elektronik**  
N Industrigaten 29  
S-314 31 Hyltebruk, Sweden

Tel: 00 46 345 10646  
Fax: 00 46 345 17074  
Car phone: 10-249 1323  
Email: rcibj@algonet.se

**Thailand**  
(Tan Hean  
Margaret Tan)

**Industrial Power Eng Sdn Bhd**  
16 Jalan SS4/17  
47301 Petaling Jaya  
Selangor, Malaysia

Tel: 00603 7747 109  
Tlx: RS 37738 PMBELA  
Fax: 00 603 7765 105  
Cables: INPOW  
Home: 00 603 7184 115  
Car phone: 011 3462 07

**USA**  
(Ed Vivian)

**British Federal North America**  
1000 N. Opdyke  
Suite "E"  
Auburn Hills, MI 48326

Tel: 001 248 371 0299  
Fax: 001 248 371 0290  
Car: 001 248 321 3933  
Email: sales@bfna.net

**Venezuela**  
(Jose Oller)

Seprotect C.A.  
Calle Columbia #92-29  
San Polas  
Valencia  
2001 Venezuela

Tel: 00 58 144 209595  
Fax: 00 58 417 16517